

# Throttle screw, series Q

Operating pressure  $p_{max} = 400$  bar  
 Flow  $Q_{max} = 80$  lpm

See also:  
 Throttles type Q, QR and QV (21...61) acc. to D 7730

## 1. General

According to DIN 1219-1, throttle valves are categorized as flow valves. Their functional task within the hydraulic circuit is to generate a variably adjustable pressure corresponding to the throttle drop characteristic, with which, for example, it is possible to control the velocity of cylinders in accumulator circuits and to limit the oil flow in control circuits etc.

The throttle valves described here are cone type throttles which are optionally available with or without a built-in check valve, so that the throttle effect is present in either both or only one flow direction. The throttle cross section is adjustable with a hexagon socket screw key after undoing a self-sealing locknut. The end of the adjustment distance is shown by a red ring marking visible on the end of the knob. Refer to sect. 5 for important notes on this.

The end of the adjustment range is indicated by a red ring marking, which can be seen at the head end of the locknut. See important note under Sec. 5.

## 2. Types available, main data

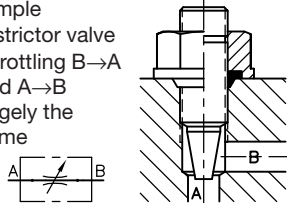
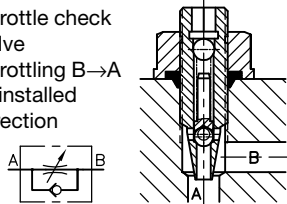
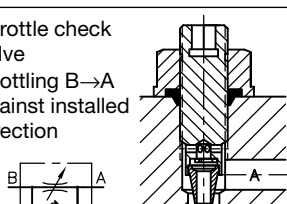
	Throttle screw for location hole	Throttle valve for installation in the pipe work 1)				Flow rate approx. $Q_{max}$ (lpm)		
		Corner valve	Banjo bolt 2)		Banjo elbow			
Pressure $p_{max}$ (bar)	Q (R, V) 2 to 5(4)..	400	400	160	400	160	400	
	Q (R, V) 6..	315	-	-	315	-	315	
Simple restrictor valve Throttling B→A and A→B largely the same 	Q 2	Q 2 T6	Q 2S	Q 2H	Q 2 S6	Q 2 H6	6	
	Q 3	Q 3 T8	Q 3S	Q 3H	Q 3 S10	Q 3 H10		
	Q 4	Q 4 T10	Q 4S	Q 4H	Q 4 S12	Q 4 H12	35	
	Q 5	Q 5 T12		Q 5H		Q 5 H16	50	
	Q 6			Q 6H		Q 6 H20	80	
Throttle check valve Throttling B→A in installed direction 	QR 2	QR 2 T6	QR 2S	QR 2H	QR 2 S6	QR 2 H6	6	
	QR 3	QR 3 T8	QR 3S	QR 3H	QR 3 S10	QR 3 H10		
	QR 4	QR 4 T10	QR 4S	QR 4H	QR 4 S12	QR 4 H12	35	
	QR 5	QR 5 T12		QR 5H		QR 5 H16	50	
	QR 6			QR 6H		QR 6 H20	80	
Throttle check valve Throttling B→A against installed direction 	QV 2	QV 2 T6	QV 2S	QV 2H	QV 2 S6	QV 2 H6	6	
	QV 3	QV 3 T8	QV 3S	QV 3H	QV 3 S10	QV 3 H10		
	QV 4	QV 4 T10	QV 4S	QV 4H	QV 4 S12	QV 4 H12	16	
	QV 5	QV 5 T12		QV 5H		QV 5 H16	25	
	QV 6			QV 6H		QV 6 H20	40	

1) Final figures 6, 8, 10, 12, 16 and 20 in the type designations are the outer diameter of the pipe to be connected

2) For EO parts to be supplied by client, see appendix, section 4.2.1

### 3. Other characteristic data

Design	Annulus throttle
Line connection	direct screw-in connection in location hole of device bodies or pipeline connections (housing design)
Installed position	as desired
Pressure fluid	Fluids acc. to DIN 51524 table 1 to 3; ISO VG 10 to 68 acc. to DIN 51519 Viscosity range: min. approx. 4mm <sup>2</sup> /s; max. approx. 1500 mm <sup>2</sup> /s Optimal operation range: approx. 10...500 mm <sup>2</sup> /sec Also suitable are biologically degradable pressure fluids of the type HEPG (Polyalkylenglycol) and HEES (synth. Ester) at operation temperatures up to approx. +70°C.
Temperatures	Ambient: approx. -40 ... +80°C Oil: -25 ... +80°C; take note of viscosity ranges! Start temperature down to -40°C are allowable (Pay attention to the viscosity range during start!), as long as the operation temperature during subsequent running is at least 20 K (Kelvin) higher. Biological degradable pressure fluids: Pay attention to manufacturer's information. With regard to the compatibility with sealing materials do not exceed +70°C.

$\Delta p$ -Q curve  
(recommended values)

The throttle setting of the valve is to be carried out by means of a pressure gauge, at the installation location always, since the back pressure ranges from  $\infty$  <sup>1)</sup> (throttle closed) to a lower limit value which is determined by the inherent resistance of the angle deflection B→A.

**Caution:** See note under sect. 5!

The flow resistance in the unblocked flow direction A→B with QR... and QV... is dependent on the throttle setting which has been selected, and is accordingly always smaller than the flow resistance according to the limit curve. If the actual  $\Delta p_{A\rightarrow B}$  value of the projection is already of interest, it can be graphically determined as a function of a preselected throttle setting  $\Delta p_{B\rightarrow A}$ , see sect. 5.2.

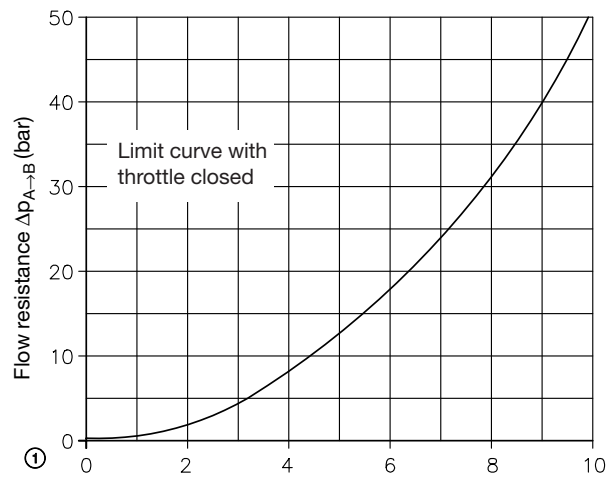
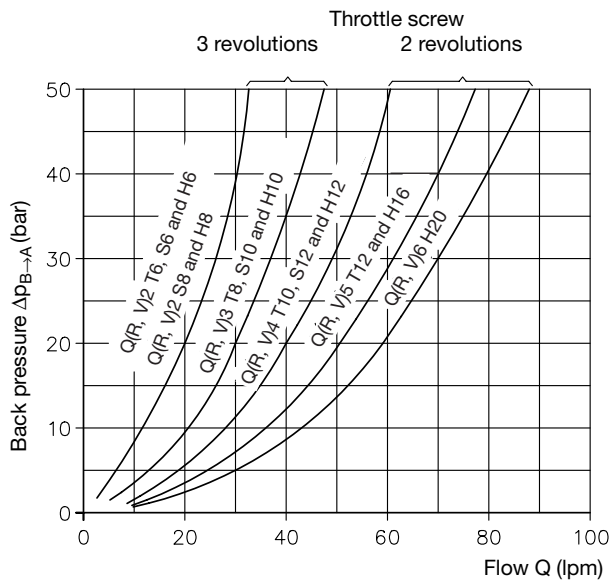

<sup>1)</sup> Theoretical value; leak-free blocking position is not guaranteed (do not force the throttle screw into the closed position). With swivel housing designs Q.. S.. and Q.. W.., a blocking position cannot be obtained because of the thread leakage at the banjo bolt. Throttle adjustments close to the blocked position are in principle to be avoided, since the minimum gap width causes the risk of blockage due to microfine particles contained in suspension in the oil.

- |                           |                      |
|---------------------------|----------------------|
| ① = QV 2 H6 and H8        | ⑥ = QR 4 T10 and S12 |
| ② = QR 2 T6 and S6 and S8 | ⑦ = QV 5 H16         |
| ③ = QV 3 H10              | ⑧ = QR 5 T12         |
| ④ = QR 3 T8 and S10       | ⑨ = QV 6 H20         |
| ⑤ = QV 4 H12              | ⑩ = QR 6             |

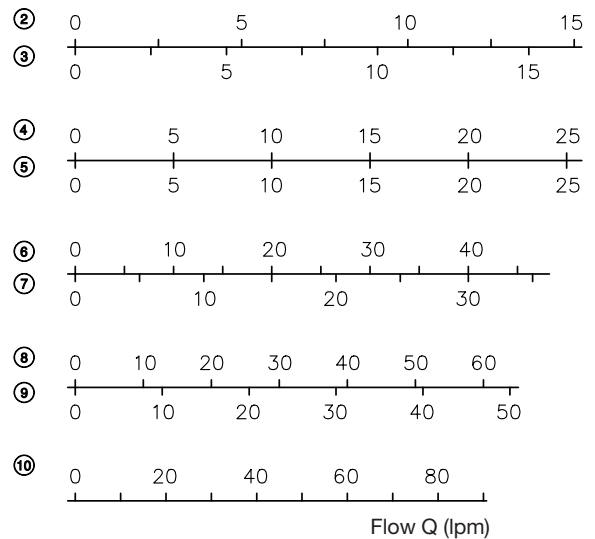

Mass (weight) approx. g

Throttle screw		Throttle valve for line installation (cutting ring screw connection)									
		Corner valve		with banjo bolt				Banjo elbow			
Type	appr. g	Type	appr. g	Type	appr. g	Type	appr. g	Type	appr. g	Type	appr. g
Q(R, V) 2	15	Q(R, V) 2 T6	100	Q(R, V) 2S	50	Q(R, V) 2H	40	Q(R, V) 2 S6 Q(R, V) 2 S8	100	Q(R, V) 2 H6 Q(R, V) 2 H8	150
Q(R, V) 3	25	Q(R, V) 3 T8	140	Q(R, V) 3 S	90	Q(R, V) 3 H	70	Q(R, V) 3 S10	170	Q(R, V) 3 H10	250
Q(R, V) 4	40	Q(R, V) 4 T10	190	Q(R, V) 4 S	110	Q(R, V) 4 H	90	Q(R, V) 4 S12	220	Q(R, V) 4 H12	290
Q(R, V) 5	60	Q(R, V) 5 T12	270	---		Q(R, V) 5 H	130	---		Q(R, V) 5 H16	470
Q(R, V) 6	90	---		---		Q(R, V) 6 H	230	---		Q(R, V) 6 H20	830

## 4. Dimensions of units

All dimensions are in mm. Subject to change without notice!

### 4.1 Throttle screw

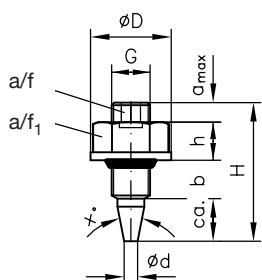

Type	G	D	H	a <sub>max</sub>	b	d	d <sub>1</sub>
Q(R) 2 QV 2	M8x1	17	28	5	8.5 5	2.8-0.1	10+0.3
Q(R) 3 QV 3	M10x1	21	36	8	11 6	3.6-0.1	12.5+0.3
Q(R) 4 QV 4	M12x1.5	24	40	10	12 7	4.6-0.1	15.5+0.3
Q(R) 5 QV 5	M14x1.5	27	44	8	15 7	5.4-0.1	16.5+0.3
Q(R) 6 QV 6	M16x1.5	30	53	6	16 7.5	6.9-0.1	19.5+0.3

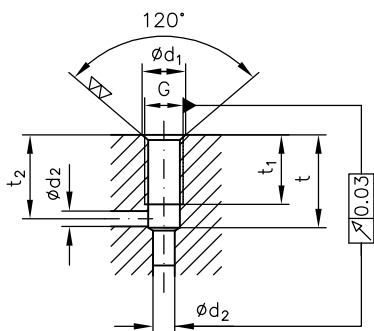

Type	d <sub>2</sub>	h	t	t <sub>1</sub>	t <sub>2</sub>	x	a/f	a/f <sub>1</sub>
Q(R, V) 2	4.2	8.5	14.5	12	12.5	20	4	13
Q(R, V) 3	5.2	9	18.5	15.5	16	20	5	17
Q(R, V) 4	7.3	10	19.5	16.5	16	25	6	19
Q(R, V) 5	8.3	11	24	20	20	25	7	22
Q(R, V) 6	9.5	17.5	27	19	23.5	25	10	24

### 4.2 Throttle valve for installation in the pipe work

#### 4.2.1 Corner valve

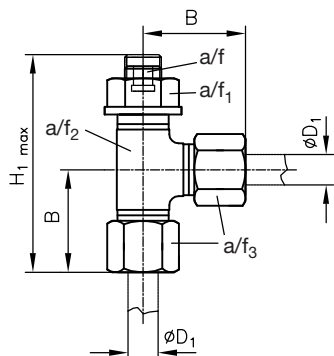

Type	B	H <sub>1</sub>	D <sub>1</sub>	a/f	a/f <sub>1</sub>	a/f <sub>2</sub>	a/f <sub>3</sub>
Q(R, V) 2 T6	31	59	6	4	13	14	17
Q(R, V) 3 T8	32	62	8	5	17	17	19
Q(R, V) 4 T10	34	71	10	6	19	19	22
Q(R, V) 5 T12	38	78	12	7	22	22	24

4.2.2 Banjo bolts

Type Q(R, V) .. S

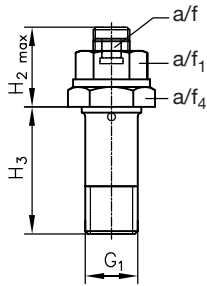

Type Q(R, V) .. H

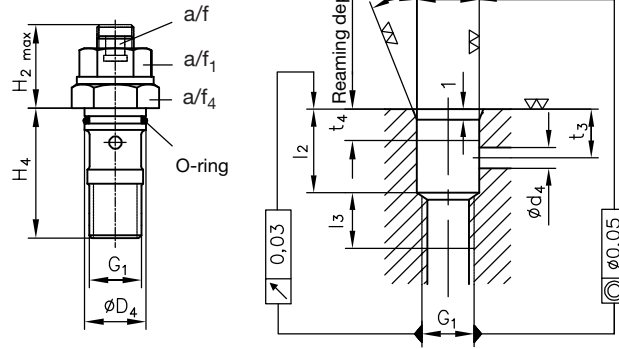

Type	G1 (BSPP)	H2	H3	H4	a/f	a/f1	a/f4
Q(R, V) 2 S(H)	G 1/4 A	21.5	32	33	4	13	19
Q(R, V) 3 S	G 1/4 A	28	36	38	5	17	22
Q(R, V) 3 H							24
Q(R, V) 4 S(H)	G 3/8 A	31	41	38	6	19	24
Q(R, V) 5 H	G 1/2 A	31.5	--	49.5	7	22	30
Q(R, V) 6 H	G 3/4 A	38	--	59.5	10	24	36

Type	G2 (BSPP)	D2	D3	d4	l	l1	t3	t4	O-ring 90 Sh
Q(R, V) 2 H	G 1/4	15.45	15.5 <sup>+0.1</sup>	5	23	10	10	7	12.5x1.5
Q(R, V) 3 H	G 3/8	18.95	19 <sup>+0.1</sup>	8	27	12	13	9	16x1.5
Q(R, V) 4 H	G 3/8	18.95	19 <sup>+0.1</sup>	12	27	12	13	9	16x1.5
Q(R, V) 5 H	G 1/2	22.95	23 <sup>+0.1</sup>	12	35	15	14	9	20x1.5
Q(R, V) 6 H	G 3/4	28.95	29 <sup>+0.1</sup>	16	43	18	20	10	25x2

4.2.3 Banjo elbow

Type Q(R, V) .. S ..

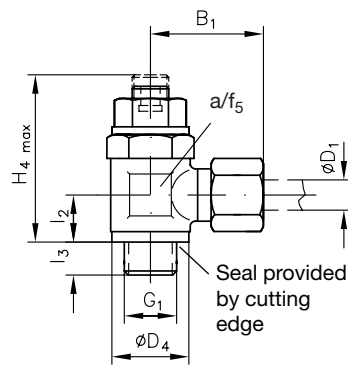

Type Q(R, V) .. H ..

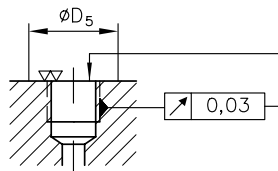
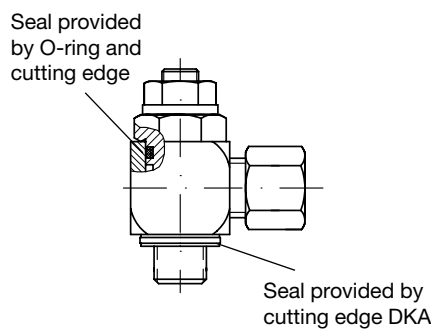

Counter bore D5  
approx. D4 + 0.5 ... 1 mm

Type	G1 (BSPP)	B1	D1	D4	H4	l2	l3	a/f5
Q(R, V) 2 S6	G 1/4 A	30	6	18	42.5	13	9	19
Q(R, V) 2 H6		31	6	18	42.5	14	9	22
Q(R, V) 2 S8	G 1/4 A	30	8	18	42.5	13	9	19
Q(R, V) 2 H8		31	8	18	42.5	14	9	22
Q(R, V) 3 S10	G 3/8 A	32	10	22	50	15	9	22
Q(R, V) 3 H10		35	10	22	54	16.5	9	27
Q(R, V) 4 S12	G 3/8 A	33	12	22	58	18	9	24
Q(R, V) 4 H12		35	12	22	58	16.5	9	27
Q(R, V) 5 H16	G 1/2 A	40	16	26	62.5	21.5	26	32
Q(R, V) 6 H20	G 3/4 A	48	20	32	78	24	32	41

For missing dimensions, see sect. 4.2.1!

List of EO components to be supplied by client

Banjo bolt	Pipe diameter	Bonjo elbow	EO components supplied by client <sup>1)</sup>			Max. torque for banjo bolt $M_{max}$ (Nm)
			Cutting edge ring	Cutting tapered ring	Union nut	
Q(R, V) 2 S	Ø 6	XSWVE 6 - SR-A3C	--	dpr 6 - S	m 6 - S	45
Q(R, V) 2 H		XWH 6 - SR-A3C	DKA 1/4			50
Q(R, V) 2 S	Ø 8	XSWVE 8 - SR-A3C	--	dpr 8 - S	m 8 - S	45
Q(R, V) 2 H		XWH 8 - SM/SR-A3C	DKA 1/4			50
Q(R, V) 3 S	Ø 10	XSWVE 10 - SM/SR	--	dpr 10 - S	m 10 - S	70
Q(R, V) 3 H		XWH 10 - SM/SR-A3C	DKA 3/8			75
Q(R, V) 4 S	Ø 12	XSWVE 12 - SR-A3C	--	dpr 12 - S	m 12 - S	70
Q(R, V) 4 H		XWH 12 - SR-A3C	DKA 3/8			75
Q(R, V) 5 S	Ø 16	XSWVE 16 - SR-A3C	--	dpr 16 - S	m 16 - S	100
Q(R, V) 5 H		XWH 16 - SR-A3C	DKA 1/2x4.5			130
Q(R, V) 6 S	Ø 20	XSWVE 20 - SM/SR	--	dpr 20 - S	m 20 - S	140
Q(R, V) 6 H		XWH 20 - SM/SR-A3C	DKA 3/4			250

1) Co. Parker Hannifin GmbH Gb (ERMETO-division), Am Metallwerk 9, D-33659 Bielefeld

## 5. Instructions for operation

### 5.1 Maximum adjustment length

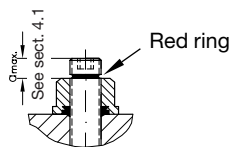

At the maximum adjustment length (guideline dimension  $a_{max}$ ), the ring marking will become visible. Further unscrewing will not achieve any further change (reduction) in the pressure cross-section influencing the  $\Delta p$  - value.

From a design point of view, an internal stop to prevent further or complete unscrewing cannot be provided. The red ring marking accordingly also represents the end of the permissible adjustment length. If it is exceeded, the number of load-bearing threads will be reduced, and if unscrewed too far there is the risk that the throttle screw might be torn out at high pressures. This point should, if necessary, be entered in the operating manual or the operating instructions for the system.

**Caution:**

Do not unscrew throttle screw beyond red marking ring!

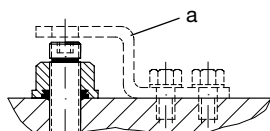

If necessary (e.g. for accident prevention), appropriate securing elements (a) are to be attached to the unit bodies into which the Q-screw is inserted, so as to prevent the screw from turning outwards any further. This also applies to housing designs as under section 4.2.

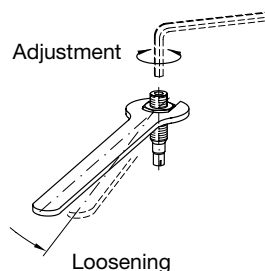

Only slight loosening of the Seal-Lock-nut is required for adjusting the throttle screw with an Allen key. This way almost no fluid will escape out of the bore.

### 5.2 Flow resistance in direction A→B with QR- and QV-valve

Check valve and throttle annulus form two parallel resistances in the direction A→B. Depending on the setting of the throttle screw  $\Delta p_{B \rightarrow A}$  selected which has been selected or has proved necessary, the flow resistance in the counter-direction  $\Delta p_{A \rightarrow B}$  will differ at a given flow rate  $Q_{given}$ . A graphic determination for any desired adjustment is possible, see example.

Example:

QR 3 8, selected operating point ①

$\Delta p_{B \rightarrow A \text{ selected}} = 40 \text{ bar bei } Q_{given} = 10 \text{ lpm}$

Accordingly, the approx. course ② of the throttle characteristic curve for this setting, and also for other flow rates  $Q_x$ , is determined

$$\Delta p_{B \rightarrow A} = \Delta p_{B \rightarrow A \text{ selected}} \cdot \left( \frac{Q_x}{Q_{given}} \right)^2 = 40 \cdot \left( \frac{Q_x}{10} \right)^2$$

This curve course and the limit line ③  $\Delta p_{A \rightarrow B \text{ limit}}$  for QR 3 T8 from sect. 3, drawn into a diagram and added above Q, gives the approximate course ④ to be anticipated for  $\Delta p_{A \rightarrow B}$  with the selected throttle setting.

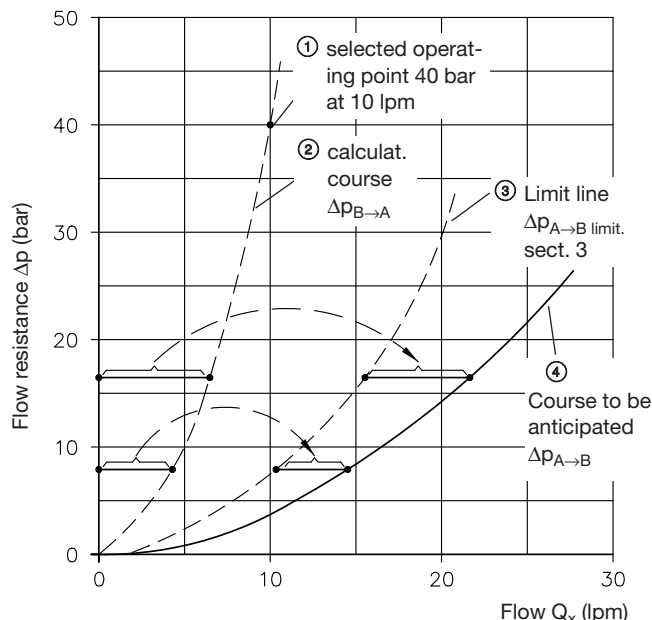

# Supplement No. 19/1

Reference: Pamphlett D 7050 covering throttle screws type Q. Release September 1987

Co. Parker Hannifin GmbH Gb (ERMETO-division) has introduced the new fittings type WH., which will replace the current type WHO (banjo elbows). Therefore type Q(R,V)..W and Q(R,V)..W... will be discontinued soon

- New: Banjo bolt type Q2H to QV6H  
 Banjo elbows type Q2H6 to QV6H20
- Discontinued: Banjo bolt type Q2W to QV6W  
 Banjo elbows type Q2W6 to QV6W20  
 Availability only as long as our stock lasts !

- Benefits of fittings type WH
1. Sealing at the mounting hole side via cutting edge ring
  2. Improved sealing due to O-ring protected in a groove of the banjo bolt and cutting edge type sealing at the top.
  3. More compact design.

## 3.2 Throttle valve for line installation

With banjo bolt, when the housing parts are customer furnished at Co. Parker Hannifin GmbH (ERMETO-division).

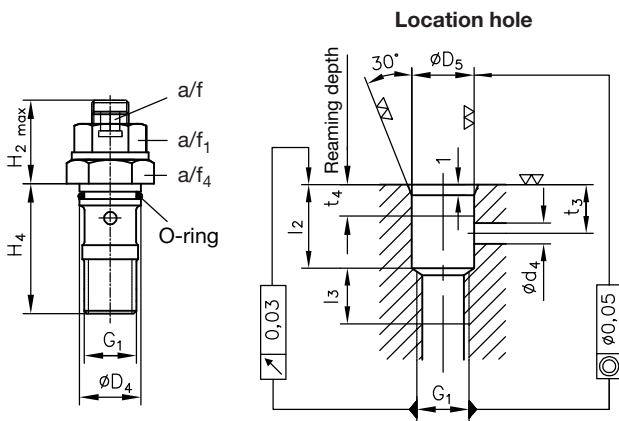

Type	G1	B1	D1	D2	D4	D5	H2
Q(R, V) 2H6	G 1/4 A	31	6	18	15.45	15.5	21.5
Q(R, V) 2H8	G 1/4 A	31	8	18	15.45	15.5	21.5
Q(R, V) 3H10	G 3/8 A	35	10	22	18.95	19	28
Q(R, V) 4H12	G 3/8 A	35	12	22	18.95	19	31
Q(R, V) 5H16	G 1/2 A	40	16	26	22.95	23	31.5
Q(R, V) 6H20	G 3/4 A	48	20	32	28.95	29	38

Banjo elbow ready for installation

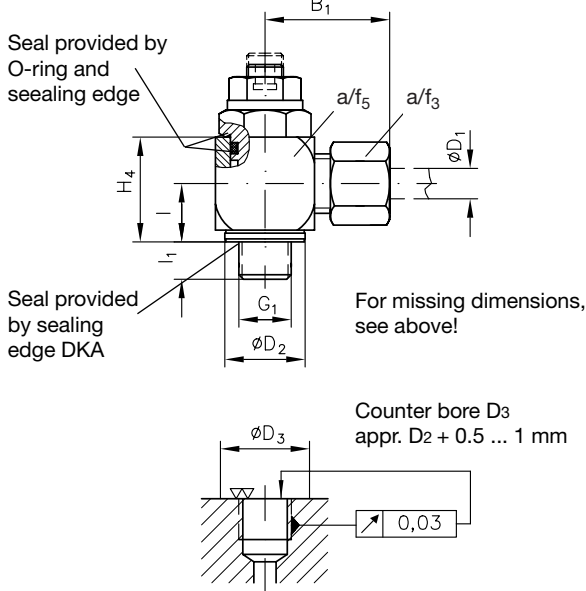

Type	H3	H4	d4	l	l1	l2	l3	t3	t4
Q(R, V) 2H6	36	21	5	14	12	23	13	10	7
Q(R, V) 2H8	36	21	5	14	12	23	13	10	7
Q(R, V) 3H10	41	26	8	16.5	12	27	15	13	9
Q(R, V) 4H12	41	26	12	16.5	12	27	15	13	9
Q(R, V) 5H16	49.5	31	12	21.5	14	35	15	14	9
Q(R, V) 6H20	59.5	40	16	24	16	43	18	20	10

Type	a/f	a/f1	a/f3	a/f4	a/f5	O-ring appr. 90 Shore
Q(R, V) 2H6	4	13	17	19	22	12.5x1.5
Q(R, V) 2H8	4	13	19	19	22	12.5x1.5
Q(R, V) 3H10	5	17	22	24	27	16x1.5
Q(R, V) 4H12	6	19	24	24	27	16x1.5
Q(R, V) 5H16	7	22	30	30	32	20x1.5
Q(R, V) 6H20	10	24	36	36	41	25x2

Changes in sect. 5 of pamphlet D 7050 (appendix)

Banjo bolt	Pipe diameter	EO components supplied by client 1)			Union nut	Max. torque for banjo bolt M <sub>max</sub> (Nm)
		Banjo elbow	Cutting edge ring	Cutting tapered ring		
Q(R, V) 2H	∅ 6	XWH 6 - SR	DKA 1/4	dpr 6 - S	m 6 - S	50
	∅ 8	XWH 8 - SM/SR	DKA 1/4	dpr 8 - S	m 8 - S	50
Q(R, V) 3H	∅ 10	XWH 10 - SM/SR	DKA 3/8	dpr 10 - S	m 10 - S	75
Q(R, V) 4H	∅ 12	XWH 12 - SR	DKA 3/8	dpr 12 - S	m 12 - S	75
Q(R, V) 5H	∅ 16	XWH 16 - SR	DKA 1/2x4.5	dpr 16 - S	m 16 - S	130
Q(R, V) 6H	∅ 20	XWH 20 - SM/SR	DKA 3/4	dpr 20 - S	m 20 - S	250

1) Co. Parker Hannifin GmbH ERMETO-division Am Metallwerk 9 D-33659 Bielefeld