

SCHIENLE

MAGNETTECHNIK

Explosion-proof solenoid coil

EX22 037 - 23W x - DC - -

Operating manual

EU Declaration of Conformity

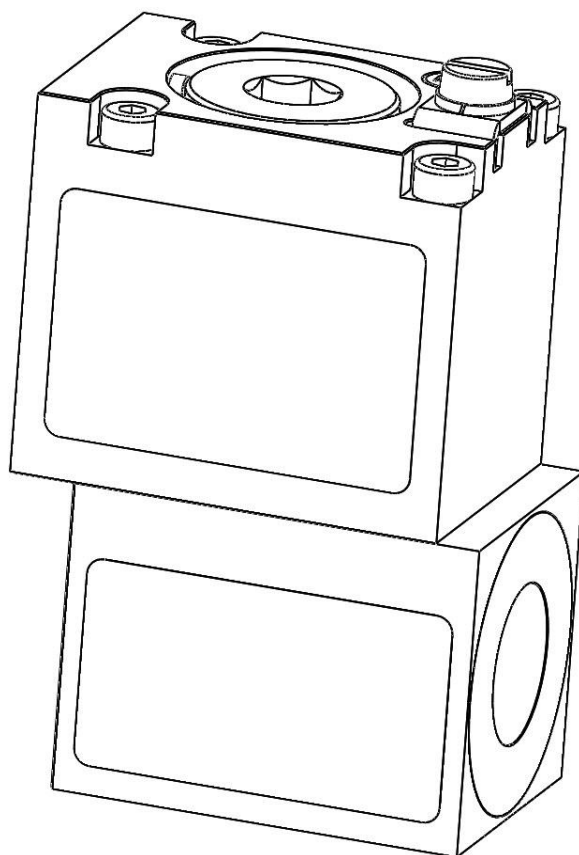

Manufacturer:

Schienle Magnettechnik GmbH
In Oberwiesen 3
88682 Salem-Neufrach
Germany

Document: B 40 / 2017
Dated: 2023
Index: 08



+49 (0)7553-8268 86
+49 (0)7553-8268 62
www.schienle.de

© Schienle Magnettechnik GmbH 2023
All rights reserved
We reserve the right to make technical
modifications

Table of contents

1	Introduction.....	3
1.1	Manufacturer.....	3
1.2	Safety.....	4
1.2.1	Intended use.....	4
1.2.2	Authorised personnel.....	4
1.2.3	Improper use.....	4
1.2.4	About this document.....	4
1.2.5	Applicable components.....	4
1.2.6	Symbols.....	4
1.3	Explanation of symbols.....	5
1.4	Abbreviations and glossary.....	5
2	General danger warnings.....	6
3	General view.....	7
4	Type identifier.....	9
4.1	Solenoid coil.....	9
4.2	Actuator.....	9
5	Technical data.....	10
6	Explosion protection.....	12
7	Operating conditions.....	13
8	Assembly.....	15
8.1	Connection to the valve.....	15
8.2	Electrical connection.....	17
8.3	Disassembly.....	18
8.4	Dimensional drawings.....	18

1 Introduction

The product was designed, manufactured and tested in compliance with current regulations and standards, and left the factory in working order and safe condition.

To maintain this condition and ensure hazard-free operation, the user must follow the notes and warnings contained in this operating manual.

1.1 Manufacturer

This product was manufactured by us:

Schienle Magnettechnik GmbH

In Oberwiesen 3

88682 Salem-Neufrach, Germany

Tel: +49 7553 8268 60

Fax: +49 7553 8268 61

Email: info@schienle.de

1.2 Safety

1.2.1 Intended use

The solenoid coil of type EX22 037 - 23W x - DC - - are intended to be used together with Schienle actuator of type: BS 19 XXX1X for actuating valves.

Operation is not permitted without the above-mentioned actuator or with actuators not of the type stated above.

The type of actuator for the valve should be selected with the solenoid coil manufacturer or their representatives. At the valve side, the installation conditions required for the magnetic solenoid coil must be guaranteed.

For details on permitted use in explosive environments, please see chapter 6.

1.2.2 Authorised personnel

The solenoid coil must only be assembled and wired by qualified and authorized expert personnel who is familiar with and observe the regulations and standards in force at the installation site.

The specific operating limits must always be adhered to. See sections 5, 6 & 7.

1.2.3 Improper use

Any other use is improper use. If the product is used beyond its specified limits, expect loss of its explosion protection.

1.2.4 About this document

This document relates to the product Explosion-proof solenoid coil , type EX22 037 - 23W x - DC - - and must always be stored so that it is immediately accessible if needed.

1.2.5 Applicable components

Only useable with the component VS M22x1 A1 (stopping plug) and BS 19 XXX1X (actuator).

1.2.6 Symbols

Safety-related notes in this document are indicated with the following symbols and signal words:



Risk of injury!

Non-compliance with the information indicated by this symbol may result in injury.



Risk of death or severe injury!

Non-compliance with the information indicated by this symbol **may** result in death or serious injury.



Risk of material damage!

Non-compliance with the information indicated by this symbol may result in machine failure etc.

1.3 Explanation of symbols

The following symbols are applied to the type plate and/or the product. The symbols must always be observed:



1.4 Abbreviations and glossary

Abbreviation	Meaning
AC	Alternating current
DC	Direct current

Table 1: abbreviations

2 General danger warnings

▲WARNING

There is no explosion protection during assembly and connection works. All works must only be carried out if no dangers are present, in particular when no explosive atmosphere is present.

Before beginning connection works and dismantling, ensure that the supply voltage is switched off and has been protected against being switched on again.

To preserve the explosion protection, ensure you observe the assembly instructions and adhere to the assembly requirements.

Before use remove all protective covers e.g. label protective film, protective caps.

3 General view

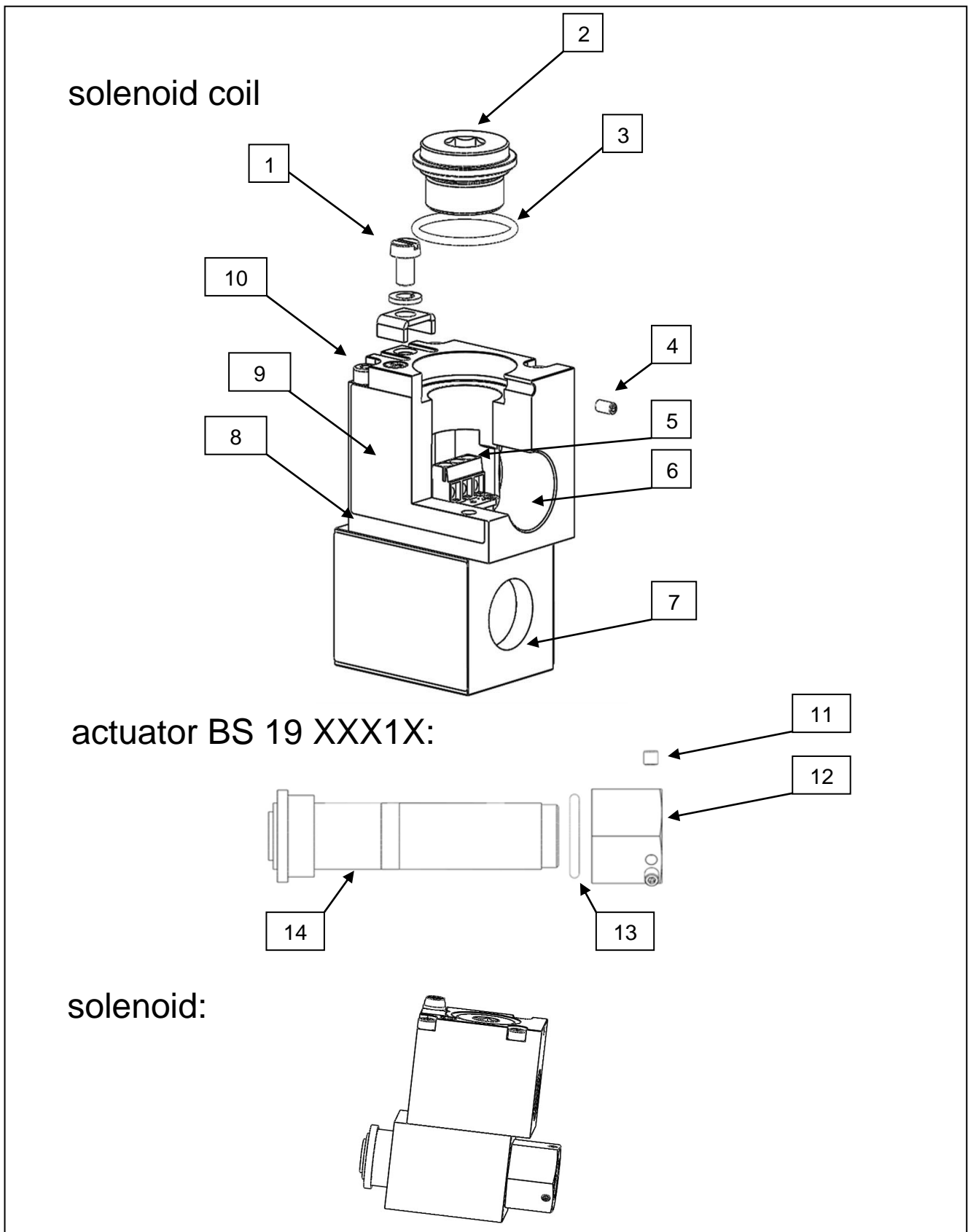

Fig 1: exploded view of the solenoid

Item no	Name	Tightening torque	Spanner size
1	screw for grounding	17 lb-in + 3.5 lb-in / 2 Nm + 0.4 Nm	Slotted screw 1.2 x 8.5
2	stopping plug – VS M22x1 A1	265 lb-in / 30 Nm	internal hex 10
3	o-ring	26 x 2 (recommended: VMQ)	
4	grub screw	26 lb-in / 3 Nm	internal hex 1.5
5	connecting terminal	4.4 lb-in / 0.5 Nm	slotted screw 0.4 x 2.5
6	thread for cable connection		
7	coil housing		
8	connector housing		
9	type label		
10	cylinder screw (4x)		
11	grub screw (1x)	26 lb-in / 3 Nm	internal hex 2
12	hexagonal nut	10 Nm	27
13	o-ring	18,72 x 2,62	
14	actuator – BS 19 XXX1X		

Table 2: parts list for exploded view

▲WARNING

It is not allowed to open the four enclosure fastener screws (10).

4 Type identifier

4.1 Solenoid coil

Type coding
EX22 037 - 23W x - DC --

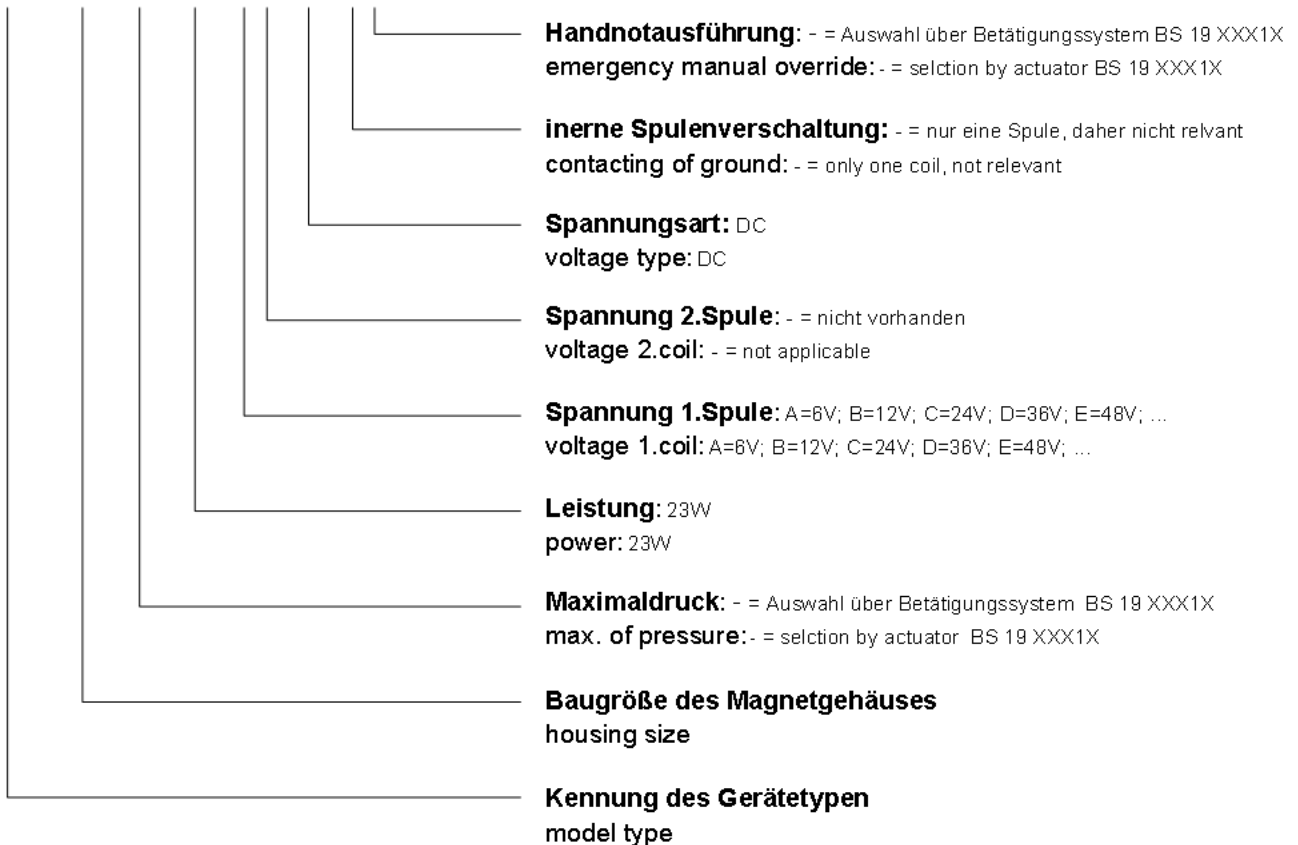

4.2 Actuator

Type coding
BS 19 X X X 1 X

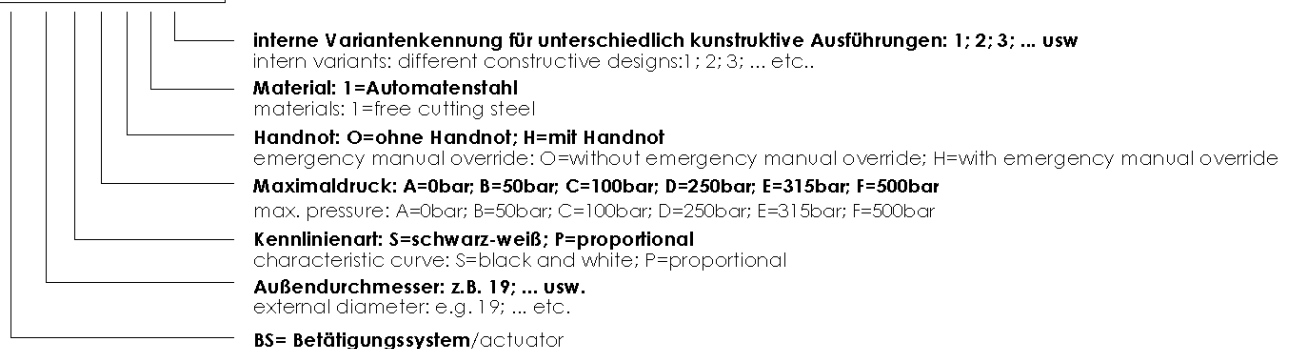

5 Technical data

Description	EX22 037 - 23W x - DC - -
Protection class according to IEC 60529	IP66/IP67
Insulation class in accordance with DIN VDE 0580	F (up to 155°C)
Highest medium temperature	70°C
Ambient temperature	-40 ≤ Ta ≤ 55°C
Supply voltage, operating current, resistance at 20°C	See table 4
Power-on time	100% exception see table 6
power	P ₂₀ ≈ 23 W
Electrical connection	
Maximum cross-section	1.5mm ²
Minimum cross-section	0.5mm ²
Protective circuit	Voltage suppressor diode

Table 3: technical data

label:

Schienle Magnettechnik und Elektronik GmbH
In Oberwiesen 3, D-88682 Salem, www.schienle.de

FM18ATEX0019X / IECEx FMG 18.0007X / FM18CA0012X

 II 2G Ex db IIB+H2 T4 Gb
II 2D Ex tb IIIC T135°C Db

CI.I Div.1 Gp B,C, D T4
CI.II Div.1 Gp E,F,G T4
CI.III Div 1&2
CI.I Zone 1, AEx db IIB+H2 T4
Zone 21, AEx tb IIIC, T135°C

-40°C ≤ t_{amb} ≤ +55°C
MWPR: see marking on actuator system

EX22 037 - 23W X - DC - -
XXVDC R20=XXΩ IG=XXA

 APPROVED



IP66/67

 2004

external fuse I_N ≤ 3I_G

Version	Voltage ±10%	Resistance ±5%	limited current	Protective circuit
	U_N	R_{20}	I_G	
	[VDC]	[Ω]	[A]	
EX22 037 - 23W B - DC - -	12	6,5	1,35	Diode
EX22 037 - 23W C - DC - -	24	25,6	0,67	Diode
EX22 037 - 23W D - DC - -	36	59	0,45	Diode
EX22 037 - 23W E - DC - -	48	105,5	0,34	Diode

Table 4: overview of variants

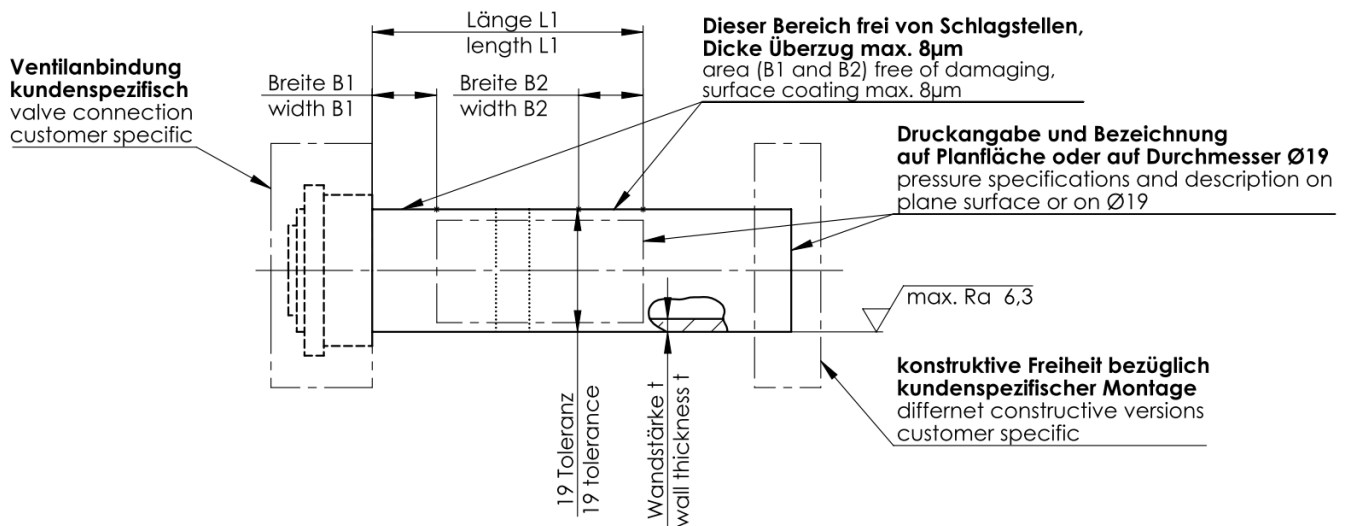

Außendurchmesser external diameter [mm]	Toleranz tolerance	Länge L1 length L1 [mm]	Breite B1 width B1 [mm]	Breite B2 width B2 [mm]	Maximaldruck maximum of pressure [bar]	Wandstärke t wall thickness t [mm]	Code
19	h8	52	10	10	0	≥ 0,1mm	BS 19 XAx1x
					50	≥ 0,5mm	BS 19 XBx1x
					100	≥ 1,0 mm	BS 19 XCx1x
					250	≥ 1,5 mm	BS 19 XDx1x
					315	≥ 1,8 mm	BS 19 XEx1x
					500	≥ 2,5mm	BS 19 XFx1x

Table 5: types of actuators

6 Explosion protection

The solenoid coil may be used in hazardous areas in accordance with the certifications:

Ambient Temperature Range: $-40^{\circ}\text{C} \leq T_a \leq 55^{\circ}\text{C}$

IP Rating: IP66/67

Certification/Approval	Type of Protection	Marking
ATEX	Ex db	II 2 G Ex db IIB+H2 T4 Gb
ATEX	Ex tb	II 2 D Ex tb IIIC T135°C Db
IECEX	Ex db	Ex db IIB+H2 T4 Gb
IECEX	Ex tb	Ex tb IIIC T135°C Db
NEC500	XP	I/1/BCDT4
NEC500	DIP	II,III/1/EFG/T4
NEC505	Aex db	I/1/Aex db IIB+H2/T4
NEC506	Aex tb	21/Aex tb IIIC/ T135°C
CEC Annex J	XP	I/1/BCD/T4
CEC Annex J	DIP	II,III/1/EFG/T4
CEC Section 18	Ex db	I/1/Ex db IIB+H2/T4
CEC Section 18	Ex tb	21/Ex tb IIIC/ T135°C

7 Operating conditions

Two solenoid coils may be used on one valve. The minimum volume of valve housing per energized solenoid coil see table 6.

As protection against short-circuiting, each solenoid coil must have a fuse fitted upstream. The fuse must be appropriate to the coil's rated voltage ($3 \times I_{nom}$, recommended $2 \times I_{nom}$ in accordance with IEC 60127-2). Alternatively, fit a thermal overcurrent release with short-circuit and thermal high-speed release (set to the rated current).

However, the fuse's rated voltage must not be greater than the power supply's short circuit current.

For thermal reasons, the solenoid coil must only be operated with a Schienle actuator of type BS 19 XXX1X and a suitable valve fitted to it.

▲WARNING

Risk of injury from explosion!

Not observing the following instructions can lead to the solenoid coil no longer being explosion-proof!

However, simultaneous energy supply to both coils results in malfunction or possible overheating, and is therefore not permitted.

No deposits that could affect heat dissipation must be allowed to build up on the solenoid coils surface.

Coating is permitted if the layer thickness does not exceed following limits:

Group IIB max. 2 mm

Group IIB+H2 max. 0.2 mm

Coating must not be used in areas affected by charge-producing processes, mechanical friction and separation processes, electron emission (e.g. in the vicinity of electrostatic coating equipment), and pneumatically conveyed dust.

Solenoid coil must be completed and fitted to the valve during the coating process.

In case of varnished surfaces: Potential electrostatic charging hazard, clean only with damp cloth.

Flame path repair is not possible. Contact manufacturer.

Before carrying out any type of works, the solenoid coil must be disconnected from the power supply.

Any type of modifications that could affect explosion-protection are strictly forbidden!

The solenoid coil must only be dismantled in non-explosive areas.

For the electrical connection, a suitable connection cable plus ½" cable gland (Ex d, at least IP66/67) or conduit system is required, which must be suitable for the intended use in accordance with 60079-14 and 60079-1. The cable and cable gland temperature range must be within the values shown in table 6.

The operator is obliged to guarantee free, unimpeded heat dissipation during operation.

During operation, the solenoid coil must neither be covered nor positioned near external heat sources.

Ensure that, during operation, the solenoid coil is not exposed to direct sunlight.

ambient temperature	valve layout	min. distance of neighboring coil housings	volume of valve	cyclic duration factor	maximum cable and cable gland temperature
≤ 40°C	series	≥ 6 mm	> 152 cm ³	100%	125°C
				75%	105°C
				50%	90°C
	single	[shaded]	> 60 cm ³	100%	105°C
				75%	90°C
				50%	90°C
≤ 55°C	series	≥ 6 mm	> 152 cm ³	100%	125°C
				75%	125°C
				50%	105°C
	single	[shaded]	> 60 cm ³	100%	125°C
				75%	105°C
				50%	90°C

Table 6: special temperature conditions

The list is only for using between directly connected actuators and steel valves.

On request other different versions, connection between actuator and valves or linking width.

To keep the temperature class the explosion-proof solenoid coil shall only be operated in combination with a valve block with minimum volume according to the operating instructions. The maximum oil temperature of 70°C shall not be exceeded.

8 Assembly

8.1 Connection to the valve

Before beginning, 'Operating conditions' and 'General danger warnings' must have been read and understood.

There is no explosion protection during assembly and connection works. All works must only be carried out if no dangers are present, in particular when no explosive atmosphere is present.

⚠ WARNING

After installation, do not open the equipment or remove components if an explosive atmosphere exists.
«ATTENTION – NE PAS OUVRIR SI UNE ATMOSPHÈRE EXPLOSIVE GAZEUSE PEUT ÊTRE PRÉSENTE»

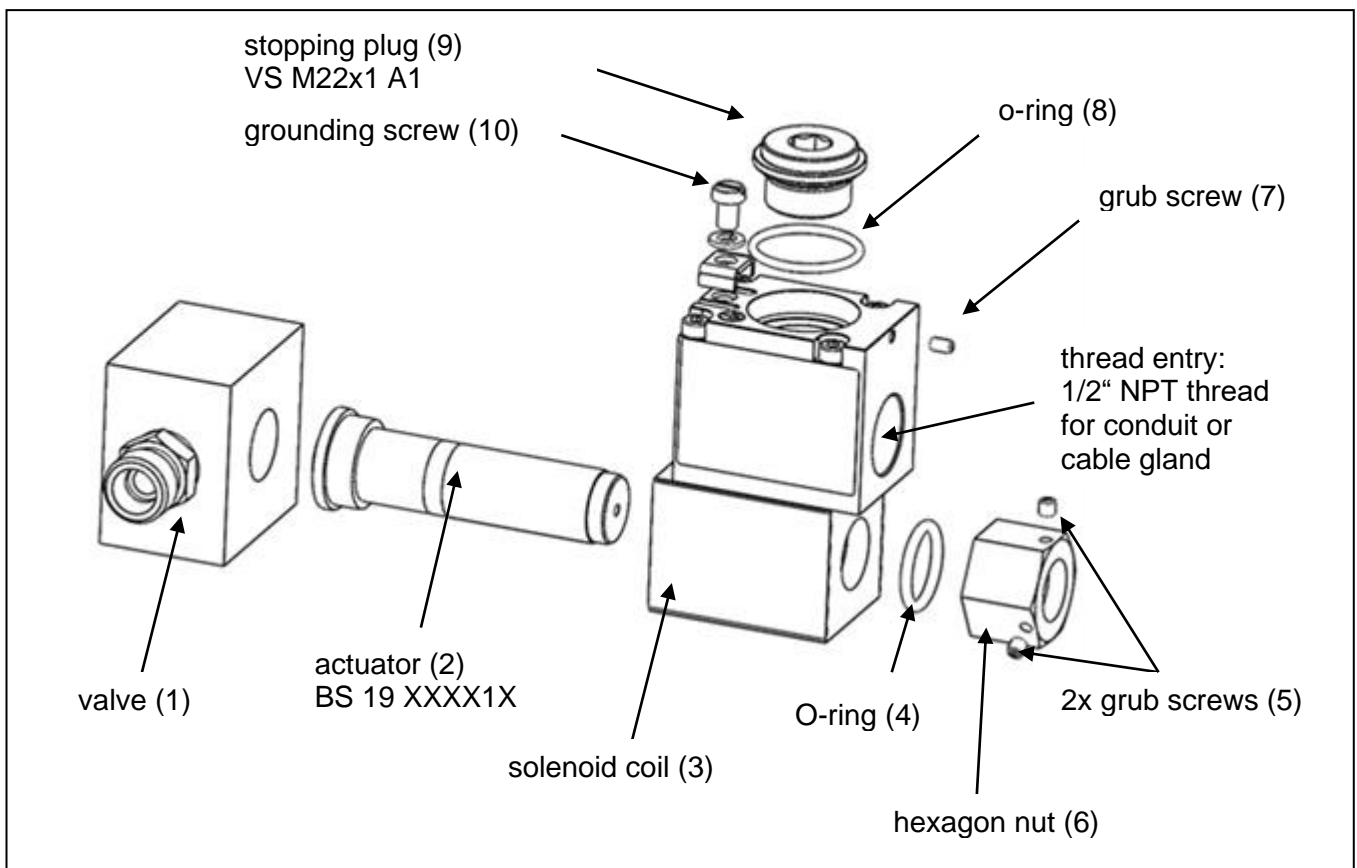

Fig 2: Assembly

See fig 2 for the order of the works when fitting the solenoid coil (3) to the actuator (2). Ensure you observe the tightening torques given in table 2.

Push the solenoid coil (3) over the actuator (2) in the order shown in fig 2 and fit the o-ring (4) and hexagon nut (6). Firmly tighten the hexagon nut (6) until it is no longer possible for the actuator to twist as a result of the expected vibrations. Secure the hexagon nut against working loose using the supplied grub screws (5). Please see table 2 for tightening torques.

▲WARNING

Solenoid coils must not be allowed to touch one another under operating conditions.

However the solenoid coils are arranged, the maximum permitted surface temperature must be guaranteed.

Connect the solenoid coil using cable entries or conduit systems that comply with the requirements of EN 60079-1 and EN 60079-14 and which have their own test certificate.

Do not use cable entries without an Ex-d test certificate!

NOTICE

The IP protection must be created by appropriate seals on the cable entries or installation pipe. Maximum IP protection class is 66/67.

▲WARNING

Conduit runs must have a sealing fitting connected within 18 inches of this coil.
UN SCELLEMENT DOIT ÊTRE INSTALLÉ À MOINS DE 457 mm DU BOÎTIER

8.2 Electrical connection

- ☞ To open the solenoid coil (fig. 2 assembly), loosen the grub screw (7) and stopping plug (9) using the tools specified in table 2. Ensure that the surrounding surfaces are dry.
- ☞ Remove the stopping plug (9). When doing so, ensure that neither the thread nor the seal become damaged or soiled.
- ☞ Connect the electrical supply to the terminal that is now accessible, in accordance with the circuit diagram (fig 3). See table 3 for permitted wire gauge and required tightening torque (tab. 2).
Depending on installation conditions, the grounding screw (10) can also be used.
- ☞ After successful electrical connection, the terminal compartment must be closed again by means of the stopping plug (9). When doing so, ensure that neither the thread nor the seal become damaged or soiled and that you observe the specified torques for the stopping plug (9) and grub screw (7) (see table 2). Tighten the grub screw and then inspect it visually to ensure it secures the stopping plug.
- ☞ Use ½" NPT cable glands or conduit system with an Ex-d test certificate for closing the housing.

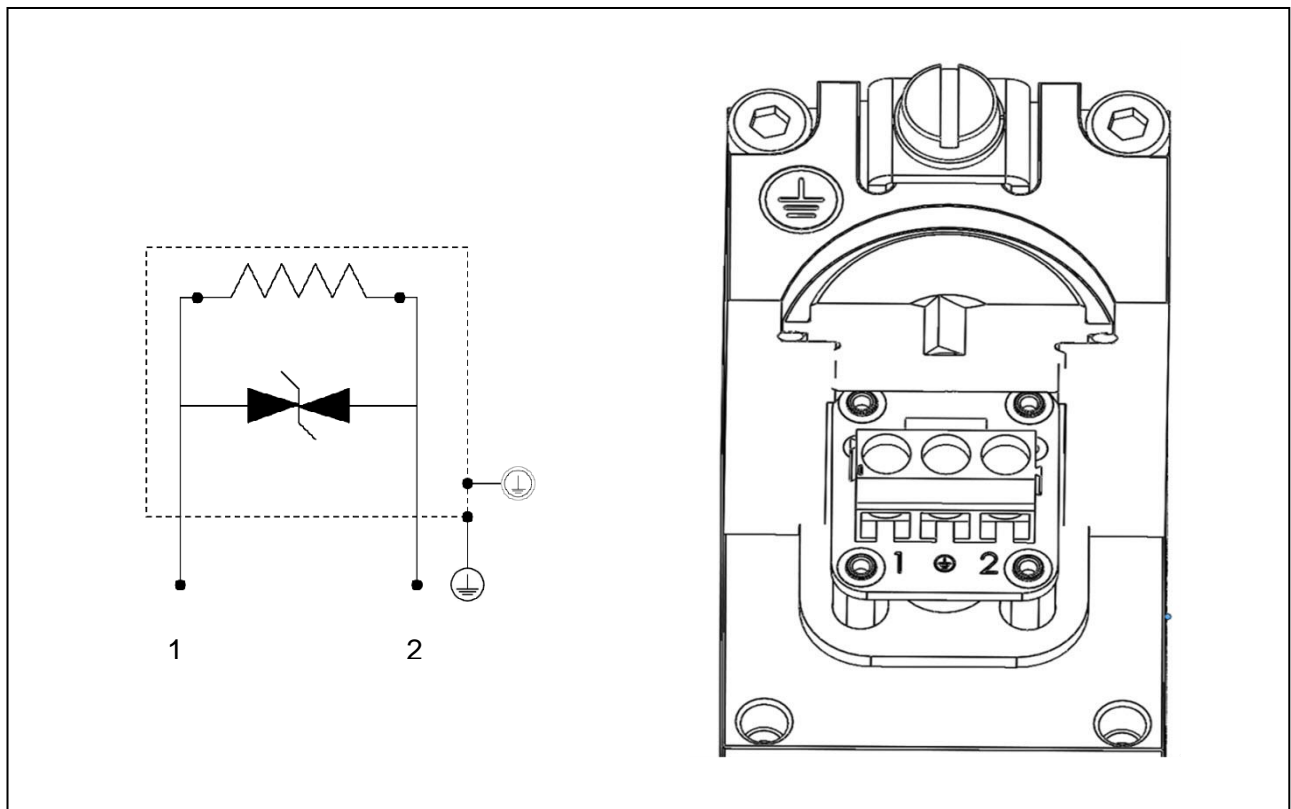

Fig 3: electrical connection

8.3 Disassembly

⚠ WARNING

Risk of injury from explosion!

When disassembled, the solenoid coil is no longer explosion-proof. Disassembly must therefore only take place in non-ignitable atmospheres!

⚠ CAUTION

Risk of injury!

During operation, the solenoid coil can become so hot that it can cause skin lesions!

- Before dismantling, allow the solenoid coil to cool down for 10 minutes.

8.4 Dimensional drawings

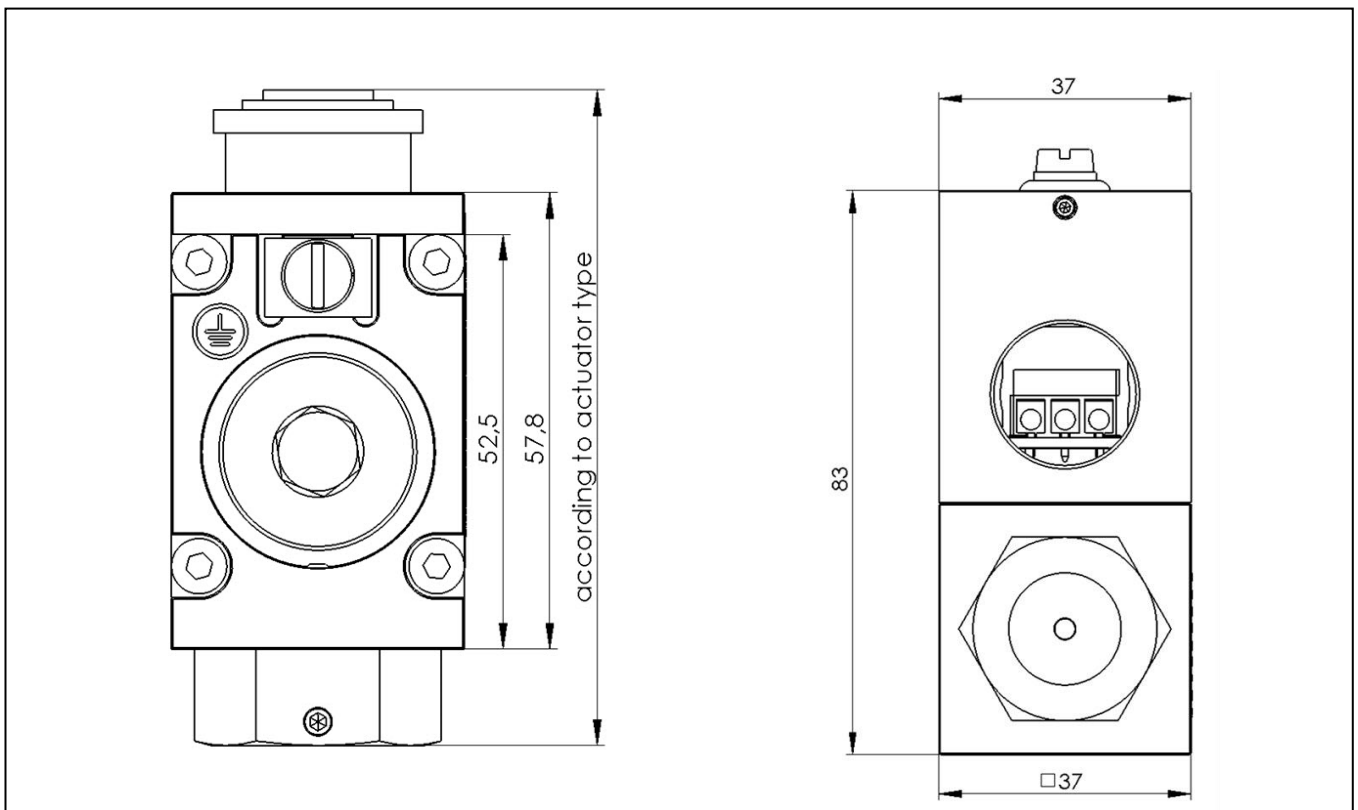



Fig 4: The coil external dimensions

EU-Konformitätserklärung
EU Declaration of Conformity (DOC)

Schienle Magnettechnik + Elektronik GmbH ; In Oberwiesen 3 ; 88682 Salem-Neufrach, Germany
Erklärt in alleiniger Verantwortung, *declares in ist sole responsibility,*

dass das Produkt: **Explosionssgeschützter Magnet**
That the product: **Explosion Proof Solenoid**
Typ(en), type(s): **EX22 037 - 23W x - DC - -**

mit den Anforderungen der folgenden Richtlinien und Normen übereinstimmt.
is in conformity with the requirements oft he following directives and standards.

Richtlinie(n) /Directice(s)	Norm(en) / Standard(s)
2014/34/EU ATEX Richtlinie 2014/34/EU ATEX Directive	EN IEC 60079-0:2018 EN 60079-1:2014 EN 60079-31:2014 EN 60529: 1991 + A1:2000 + A2:2013 DIN VDE 0580:2011
Kennzeichnung, marking	 II 2G Ex db IIB+H2 T4 Gb  II 2D Ex tb IIIC T135°C Db
EU-Baumusterprüfbescheinigung: EU Type Examination Certificate:	FM18ATEX0019X



21.11.2022
Ort und Datum
Place and date

P. M.
Explosionsschutzbeauftragter
Explosion protection representative

[Signature]
stellv. Geschäftsführer
Vice Managing Director