

# Flow control valve type CSJ

## Product documentation



Screw-in valve

Operating pressure  $p_{\max}$ : 420 bar

Flow rate  $Q_{\max}$ : 2.3 lpm



© by HAWE Hydraulik SE.

The reproduction and distribution of this document as well as the use and communication of its contents to others without explicit authorisation is prohibited.

Offenders will be held liable for the payment of damages.

All rights reserved in the event of patent or utility model applications.

Brand names, product names and trademarks are not specifically indicated. In particular with regard to registered and protected names and trademarks, usage is subject to legal provisions.

HAWE Hydraulik respects these legal provisions in all cases.

Printing date / document generated on: 15.11.2017

<b>1</b>	<b>Overview of 2-way flow control valves type CSJ.....</b>	<b>4</b>
<b>2</b>	<b>Available versions, main data.....</b>	<b>5</b>
2.1	Basic type.....	5
2.2	Version with connection block for pipe connection.....	5
<b>3</b>	<b>Parameters.....</b>	<b>6</b>
3.1	General information.....	6
<b>4</b>	<b>Dimensions.....</b>	<b>8</b>
4.1	Basic type (cartridge valve).....	8
4.2	Mounting hole.....	8
4.3	Version with single connection block.....	9
4.4	Tapped plugs.....	9
<b>5</b>	<b>Assembly, operation and maintenance recommendations.....</b>	<b>10</b>
5.1	Intended use.....	10
5.2	Assembly information.....	10
5.2.1	Screw in basic type (cartridge valve).....	11
5.2.2	Adjusting volumetric flow.....	11
5.2.3	Creating the mounting hole.....	11
5.3	Operating instructions.....	12
5.4	Maintenance information.....	12

**1****Overview of 2-way flow control valves type CSJ**

Flow control valves are a type of flow valve. They generate a set constant flow rate, largely independently of the load.  
The flow control valve type CSJ is a screw-in valve. These valves can be screwed into the easily produced threaded holes.

**Features and benefits:**

- Oscillation damping and load-independent
- Compact screw-in valve

**Intended applications:**

- General hydraulic systems
- Industrial trucks
- Lifting equipment



*Basic version (cartridge valve)*

## 2 Available versions, main data

### 2.1 Basic type

Symbol:

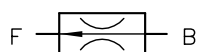

Order examples:

CSJ 0	1	-0,4	
CSJ 0	7	-2,2	-1/4

**Port** Table 2 Design with single connection block

**Response flow** Set response flow [lpm]

**Flow setting** Table 1: Basic type and response flow

**Basic type and size** Table 1: Basic type and response flow

**Table 1: Basic type and response flow**

Basic type and size	Response flow Q from ... to (lpm)			
	1	3	5	7
CSJ 0	0.25 ... 0.5	0.6 ... 1.0	1.1 ... 1.6	1.7 ... 2.3

### 2.2 Version with connection block for pipe connection

CSJ 0	5	-1,5	-1/4
-------	---	------	------

**Port** Table 2 Design with single connection block

**Response flow** Set response flow

**Flow setting** Table 1 Type and response flow

**Type and size** Table 1 Type and response flow

**Table 2 Version with single connection block**

Coding	Description	Symbol (example)
No designation	Cartridge valve	See <a href="#">Chapter 2.1, "Basic type"</a>
-1/4	For pipe connection G 1/4 (BSPP)	
-3/8	For pipe connection G 3/8 (BSPP)	

### 3.1 General information

<b>Description</b>	2-way flow control valve
<b>Design</b>	Flow control valve
<b>Model</b>	Cartridge valve, valve for pipe connection
<b>Material</b>	Steel; nitrided valve housing, electrogalvanised sealing nuts and connection block, hardened and ground functional inner parts Balls made of rolling bearing steel
<b>Installed position</b>	Any
<b>Ports</b>	<ul style="list-style-type: none"> <li>▪ B = input (on the pump side or primary side)</li> <li>▪ F = Consumer (secondary side)</li> </ul> <p>Markings apply to hydraulic schematics and assembly plans only. The markings are not stamped onto the valve housing. The coding can be found in the schematic overviews or the dimension diagrams in <a href="#">Chapter 4, "Dimensions"</a>.</p>
<b>Flow direction</b>	Operating direction B→F: regulated constant flow Return flow F→B: possible, see $\Delta p$ -Q characteristics
<b>Hydraulic fluid</b>	Hydraulic oil: according to Part 1 to 3; ISO VG 10 to 68 according to DIN ISO 3448 Viscosity limits: min. approx. 4, max. approx. 1500 mm <sup>2</sup> /s opt. operation approx. 10... 500 mm <sup>2</sup> /s. Also suitable for biologically degradable hydraulic fluids type HEPG (polyalkylene glycol) and HEES (synthetic ester) at operating temperatures up to approx. +70°C.
<b>cleanliness level</b>	<b>ISO 4406</b> <hr/> 21/18/15...19/17/13
<b>Temperature</b>	Ambient: approx. -40 ... +80°C, Fluid: -25 ... +80°C, Note the viscosity range! Permissible temperature during start: -40°C (observe start-viscosity!), as long as the service temperature is at least 20K higher for the following operation. Biologically degradable pressure fluids: Observe manufacturer's specifications. By consideration of the compatibility with seal material not over +70°C.

### Pressure and flow

<b>Operation pressure</b>	$p_{max} = 420 \text{ bar}$
<b>Static overload nominal volume</b>	Approx. $2 \times p_{max}$ – tightened and sealing nut locked
<b>Flow</b>	See <a href="#">Chapter 2.1, "Basic type"</a> Table 1

**Curves**

Oil viscosity approx. 60 mm<sup>2</sup>/s

**Caution**  
 **Risk of injury due to unexpected movement processes in the machine due to incorrect flow setting!**  
 Risk of minor injury

- Be prepared for unexpected, fast movements. On changing the flow settings, consumers will move more slowly or more quickly.
- Always monitor the pressure gauge when setting or changing the flow.

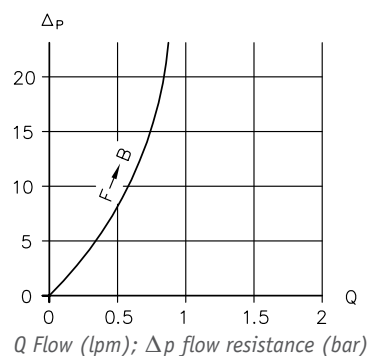
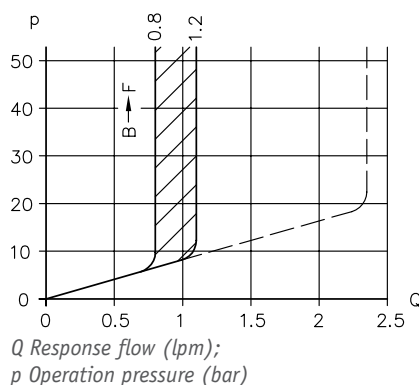

**Note**  
 For this purpose, please also observe the additional information under the point "Flow direction".

**Weight**

**Basic version**

Type  
CSJ 0 = 80 g

**Version with single connection block**

Coding  
-1/4 = + 260 g  
-3/8 = + 260 g

## 4 Dimensions

All dimensions in mm, subject to change.

### 4.1 Basic type (cartridge valve)

CSJ 0

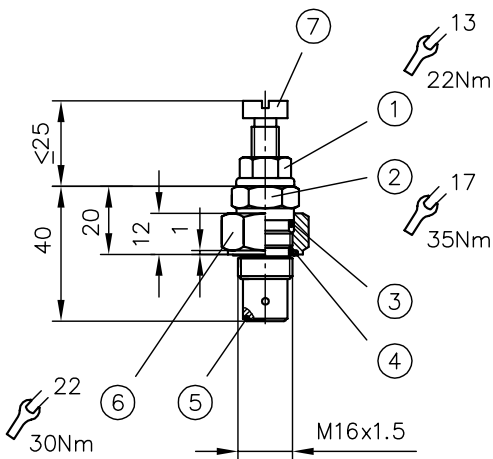

- 1 Lock nut
- 2 Valve housing
- 3 O-ring 14x1.79 AU 90 Sh
- 4 Kantseal DKAR0016-N90
- 5 O-ring 8x1.5 NBR 90 Sh
- 6 Sealing nut
- 7 Set screw

### 4.2 Mounting hole

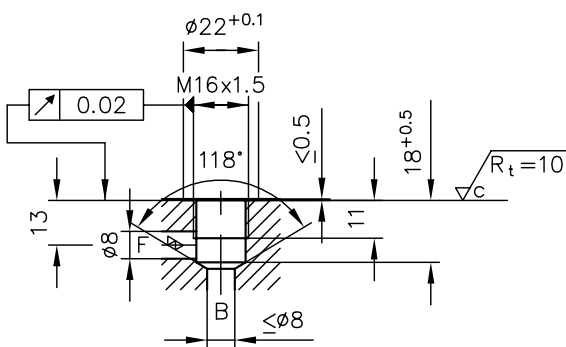

#### Kurzanleitung Ventile Aufnahmebohrung

Location for sealing (inlet to outlet): at the contact area between the facial sealing edge of the tapped journal of the valve housing and the stepped shoulder of the tapping hole of the location thread.

The stepped shoulder is depicted with the normal 118° drill tip angle for steel.

Therefore reaming of the hole and bevels to help the seals slip in are not necessary.

The sealing of the attached valve and its fixing at the manifold body are made by a sealing nut with a fitting seal and an O-ring. Additionally the passage between port A and T is sealed at the screwin port and the internal piston.



### 4.3 Version with single connection block

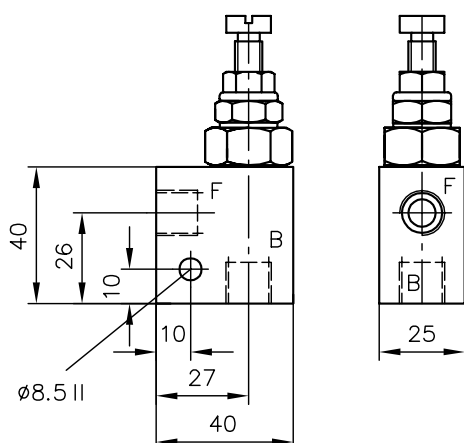

Ports F and B (ISO 228-1) (BSPP)

CSJ 0 - .. 1/4	G 1/4
CSJ 0 - .. 3/8	G 3/8

### 4.4 Tapped plugs

The mounting holes can be sealed with tapped plugs if necessary; for example, if the assembly of standardised basic bodies is to be carried out with or without screw-in valves as required.

#### Passage open

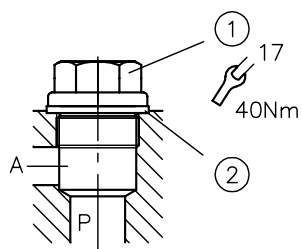

- 1 Tapped plug M16x1.5 DIN 910
- 2 Sealing ring A16.7x22x2 DIN 7603-Cu

#### Passage closed

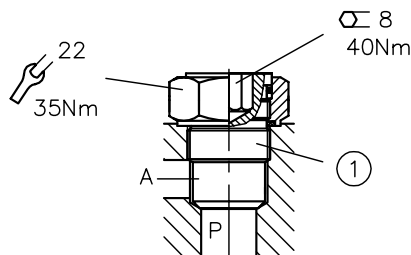

- 1 Tapped plug and locking tapped plug complete

Order number 7712 003

### 5.1 Intended use

This valve is exclusively intended for hydraulic applications (fluid engineering).

The valve demands high technical safety standards and regulations for fluid engineering.

The user must observe the safety measures and warnings in this documentation.

#### Essential requirements for the product to function correctly and safely:

- All information in this documentation must be observed. This applies in particular to all safety measures and warnings.
- The product must only be assembled and put into operation by qualified personnel.
- The product must only be operated within the specified technical parameters. The technical parameters are described in detail in this documentation.
- The operating and maintenance manual of the specific complete system must also always be observed.

If the product can no longer be operated safely:

1. Remove the product from operation and mark it accordingly
- ✓ It is then not permissible to continue using or operating the product

### 5.2 Assembly information

The product must only be installed in the complete system with standard and compliant connection components (screw fittings, hoses, pipes, etc.).

The hydraulic power pack must be shut down correctly prior to dismantling; this applies in particular to power packs with hydraulic accumulators.

**Danger**

**Risk to life caused by sudden movement of the hydraulic drives when dismantled incorrectly!**

Risk of serious injury or death.

- Depressurise the hydraulic system.
- Perform safety measures in preparation for maintenance.

## 5.2.1 Screw in basic type (cartridge valve)

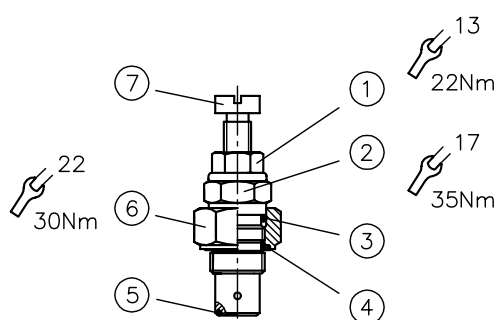

- 1 Lock nut
- 2 Valve housing
- 3 O-ring
- 4 Kantseal
- 5 O-ring
- 6 Sealing nut
- 7 Set screw

1. in the valve, loosen the lock nut and sealing nut until the travel stop. Do not fully undo the lock nut, as the lock nut fixes the set screw in position. The flow rate is set using the set screw.
2. Screw in the valve and tighten with the specified torque. The metallic sealing of the inlet to the outlet is formed between the facial sealing edge of the valve and the shoulder of the stepped hole in the basic body.
3. lock nut and sealing nut with specified torque.

## 5.2.2 Adjusting volumetric flow

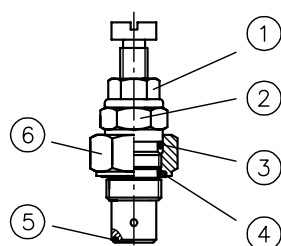

- 1 Lock nut
- 2 Valve body
- 3 O-ring
- 4 KANTSEAL
- 5 O-ring
- 6 Sealing nut
- 7 Set screw

1. Loosen lock nut
2. Turn set screw (in = increase flow rate, out = reduce flow rate)
3. Tighten lock nut

## 5.2.3 Creating the mounting hole

See also description in [Chapter 4.2, "Mounting hole"](#)

## 5.3 Operating instructions

### Product configuration and setting the pressure and flow rate

The statements and technical parameters in this documentation must be strictly observed.  
The instructions for the complete technical system must also always be followed.

#### Note

- Read the documentation carefully before usage.
- The documentation must be accessible to the operating and maintenance staff at all times.
- Keep documentation up to date after every addition or update.



#### Caution

##### **Risk of injury due to unexpected movement processes in the machine due to incorrect flow setting!**

Risk of minor injury

- Be prepared for unexpected, fast movements. On changing the flow settings, consumers will move more slowly or more quickly.
- Always monitor the pressure gauge when setting or changing the flow.

### Purity and filtering of the hydraulic fluid

Fine contamination can significantly impair the function of the hydraulic component. Contamination can cause irreparable damage.

#### Examples of fine contamination include:

- Metal chips
- Rubber particles from hoses and seals
- Dirt due to assembly and maintenance
- Mechanical debris
- Chemical ageing of the hydraulic fluid

#### Note

Fresh hydraulic fluid from the drum does not always have the highest degree of purity. Under some circumstances the fresh hydraulic fluid must be filtered before use.

Adhere to the cleanliness level of the hydraulic fluid in order to maintain faultless operation.  
(Also see cleanliness level in [Chapter 3, "Parameters"](#)).

## 5.4 Maintenance information

This product is largely maintenance-free.

Check that the product is securely fastened in the mounting hole at regular intervals, but at least once per year.

Conduct a visual inspection at regular intervals, but at least once per year, to check if the hydraulic connections are damaged. If external leakages are found, shut down and repair the system.

Clean the device surface of dust deposits and dirt at regular intervals, but at least once per year.

## Further information

### Additional versions

- Pressure valve type CMV, CMVZ, CSV and CSVZ: D 7710 MV
- Pressure-controlled shut-off valve type CNE: D 7710 NE
- Throttle valve and shut-off valve CAV: D 7711
- Check valve type CRK, CRB and CRH: D 7712
- Throttle valve and throttle check valve type CQ, CQR and CQV: D 7713
- Pressure-reducing valve type CDK: D 7745
- Pressure-reducing valve type CLK: D 7745 L
- Pressure-dependent shut-off valve type CDSV: D 7876
- Flow control valve (lowering brake valve) type SB and SQ: D 6920
- Flow control valve type SJ: D 7395